

Reduced Maintenance
Fault-free connections
Eaton Green Team
Reduced engineering expense
Easy Operation
High Flexibility
Scalable and Open
Reduced downtimes
Efficient planning and engineering

**Novaflow Engineering &
Eaton Green Team Solutions
for**

Palm Oil Industry

Lean Connectivity to Lean Automation
High availability
Fast Commissioning
Data Transparency
Improved Cost Effectiveness
Reduced engineering expenses
Distributed Intelligence
Secure Manipulation-proof
Extreme reliability
High Flexibility

One Integrated Hydraulics, Automation & Electrical Solutions in Palm Oil Mill



EAT•N

Powering Business Worldwide

NOVAFLOW
ENGINEERING

**Power Management Solutions
Power Transmissions + Control +
Steam Utilization**

Power Transmission (Hydraulics)

Novaflo Engineering's vast experience in performance hydraulic system design is available to meet your exact requirements & specifications. Please consult us with your specific needs without obligation.



Horizontal Double Door Sterilizer (Indexing Systems for Cage Movement)

Indexing system as Cage material handling that eliminates the need & use of tractors, bulldozers, capstans & winches of for Horizontal Sterilizer with Double Doors in Sterilizer Station. The systems is for owner looking for a process controlled instead of human dependable in sterilizer station. Typical Cage size used varies from 10ton; 15ton; 17.5ton to 20ton and Sterilizer Diameter of 2700mm and 3200mm. Eaton has successfully completed various projects with variety of different layouts to suit the final mill capacities.

Indexing system is a total material handling solutions in sterilizer station. The latest generation is less maintenance, bumper-to-bumper cage movement for single cage and/or twin cage movement. most efficient compact, modular, continuous material handling system for the sterilization process to perform synchronization and control of equipment from fruit reception (loading ramp) to sterilizer station and to threshing and press station, leading to improvement in productivity and consistency in throughput. A platform on top of the sterilization process with a good view of the production area.

The indexer system package provides you with a total engineered solutions on various equipment for material handling of Fresh Fruit Bunches :

- Loading Ramp via FFB Conveyors to Feeding Point
- FFB Cage Feeding to Dry End Transfer Carriage
- Dry End Transfer Carriage to move in FFB Cages to Sterilizer
- Moving out SFB Cages from Sterilizer to Wet End Transfer Carriage
- Wet End Transfer Carriage to Cage Tipper, to SFB Hopper, via SFB Conveyor to Threshing Station
- Moving Empty Cage from Tipper to Feeding Point

Some of important recognized benefits are:

- Improvement in working conditions and safety for operators as well as reducing manual handling of the cages.
- Ease of monitoring: Monitoring of movement of indexer is via Eaton Automation system. Control Panel grouping are available via **Integrated Indexing Systems** or **Simple Indexing Systems**. Remote Console Panel controls different equipment to perform multiple functions as well as interlocking.
- Low maintenance cost: Reduced wear and tear by good & precise cage movement
- Ease of operation: Easy to operate using a single touch control on push buttons as well as HMIs on Remote Consoles
- Control: Auto/Manual/By-Pass -- Auto mode will move the hydraulic cylinder on indexer to forward and backward stroke until the cage moves forward by a distance of cage length. Manual operation would require operator to operate via push buttons on Remote Consoles. By-pass operation is for operator to operate via Local Panels nearby each grouping of equipment.

Eaton scope of offer varies as following:

- Supplier of Power Transmission related and Control Panel related equipment
- A comprehensive value added project works from designing layout, mechanical works and drawings, design calculation, time and motion analysis to mobilization of team in integration of mechanical works to civil footprints; grouping of power transmission and hydraulic driven equipment; grouping of Control and Panels for operation for process controlled of material handling and sterilizer automation.

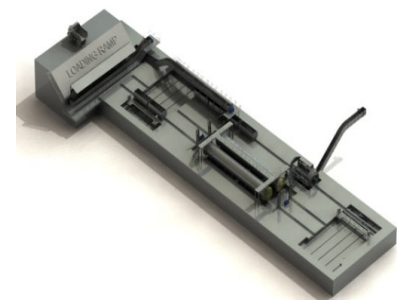
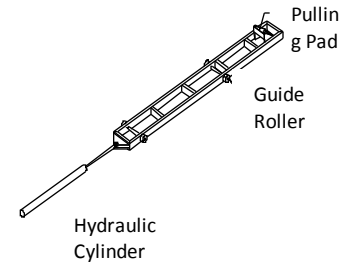

Control Grouping of a typical TwinCage 60tph Sterilizer Station

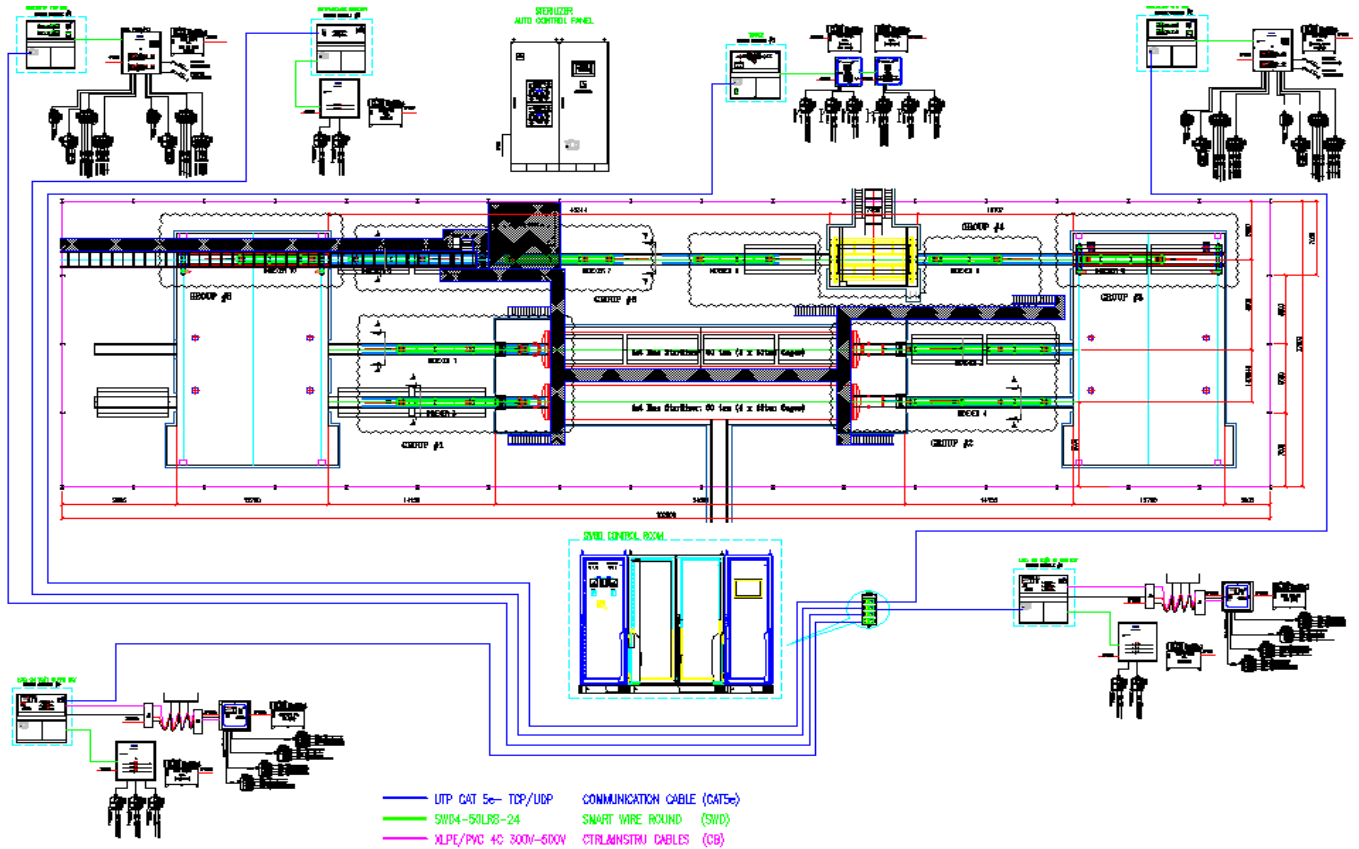

Hydraulics Grouping of a typical TwinCage 60/90tph Sterilizer Station

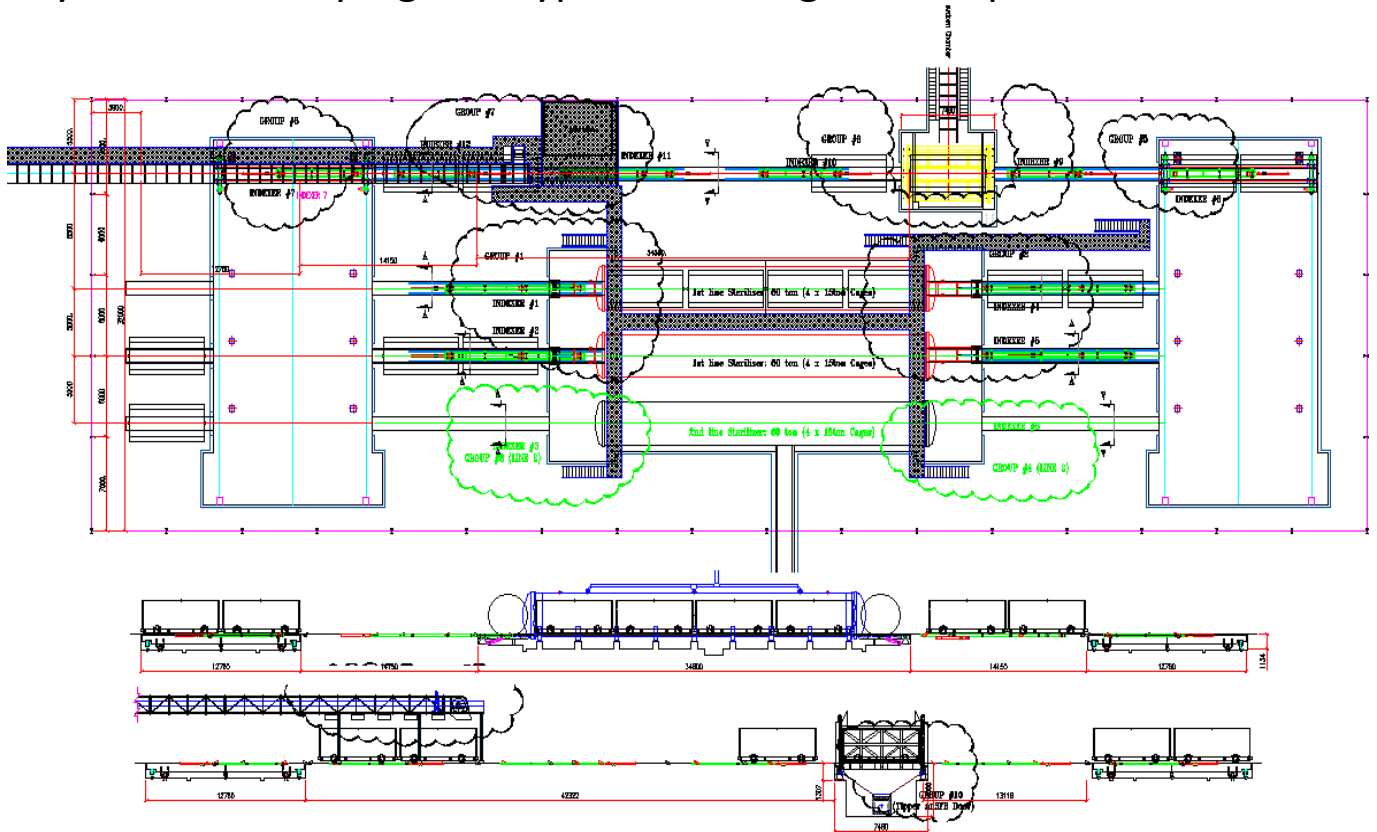

Horizontal Single Door Sterilizer (CMC Systems for Cage Movement)

CMC systems as Cage material handling for Horizontal Sterilizer with Single Door in Sterilizer Station for owner looking for an enhanced automated material handling and steam management process controlled in a smaller foot print area. Typical Cage size used is 10ton for a single door 20ton Sterilizer or 15ton for a 30ton Sterilizer, with diameter of 2700mm and 3200mm, respectively. Eaton has successfully completed various semi-turnkey CMC projects. The Modular design is suitable for a 20tph to 120tph mill.

CMC systems derived the cage movement from earlier generation Indexer system. Indexer movement is based on twin cage. As the building footprint is small, thus this is compact, modular, continuous run material handling system for the sterilization process to perform synchronization and control of flow of FFB from loading ramp to sterilizer station and then to threshing and press station. This leads to significant improvement in productivity and enhanced throughput. A platform on top of the sterilization process with a good view of the production area

This package provides you with an enhanced total engineered solutions on various mechanical; power transmission and automation equipment from loading ramp station to Threshing Station to the following flow:

- Loading Ramp via various FFB Conveyors to Feeding Point
- Feeding Point is utilizing FFB Hopper as storage buffer for Tipper
- Moving out SFB Cages from Sterilizer to Tipper via Indexer
- Tipper to SFB Hopper, via SFB Conveyor to Threshing Station
- FFB Hopper to fill empty Cage in Tipper
- Moving in FFB Cages from Tipper to Sterilizer via Indexer

Some of important recognized benefits are:

- Automated process of continuous flow and integration of material handling to sterilization process
- Less cage movement due to smaller footprint area
- Improvement in working conditions and work safety for operators;
- Ease of monitoring: Monitoring of movement of indexer is via Eaton Automation system. Remote Consoles from a **central location** in an elevated Platform for operation and monitoring of all different equipment to perform multiple functions as well as interlocking.
- Low maintenance cost: Reduced wear and tear by good & precise cage movement
- Ease of operation: Easy to operate using a single touch control on push buttons as well as HMIs on Remote Consoles
- Control: Auto/Manual. Auto mode will move the hydraulic cylinder on indexer to forward and backward stroke until the cage moves forward by a distance of cage length. Manual operation would require operator intervention to move indexer to a distance required.

Eaton scope of offer varies in a comprehensive value added project works from designing layout, mechanical works and drawings, design calculation, time and motion analysis to mobilization of team in integration of mechanical works to civil footprints; grouping of power transmission and hydraulic driven equipment; grouping of Control and Panels for operation for process automation.

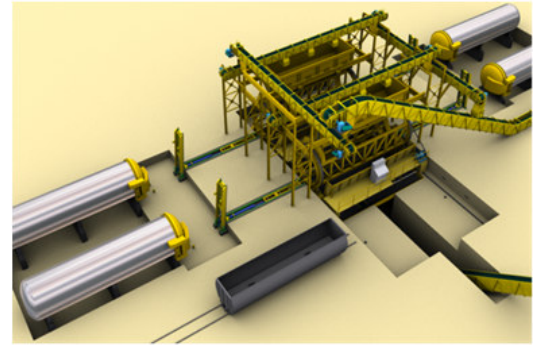

General Assembly of CMC 60tph (Modular 6 x 20ton Sterilizer)

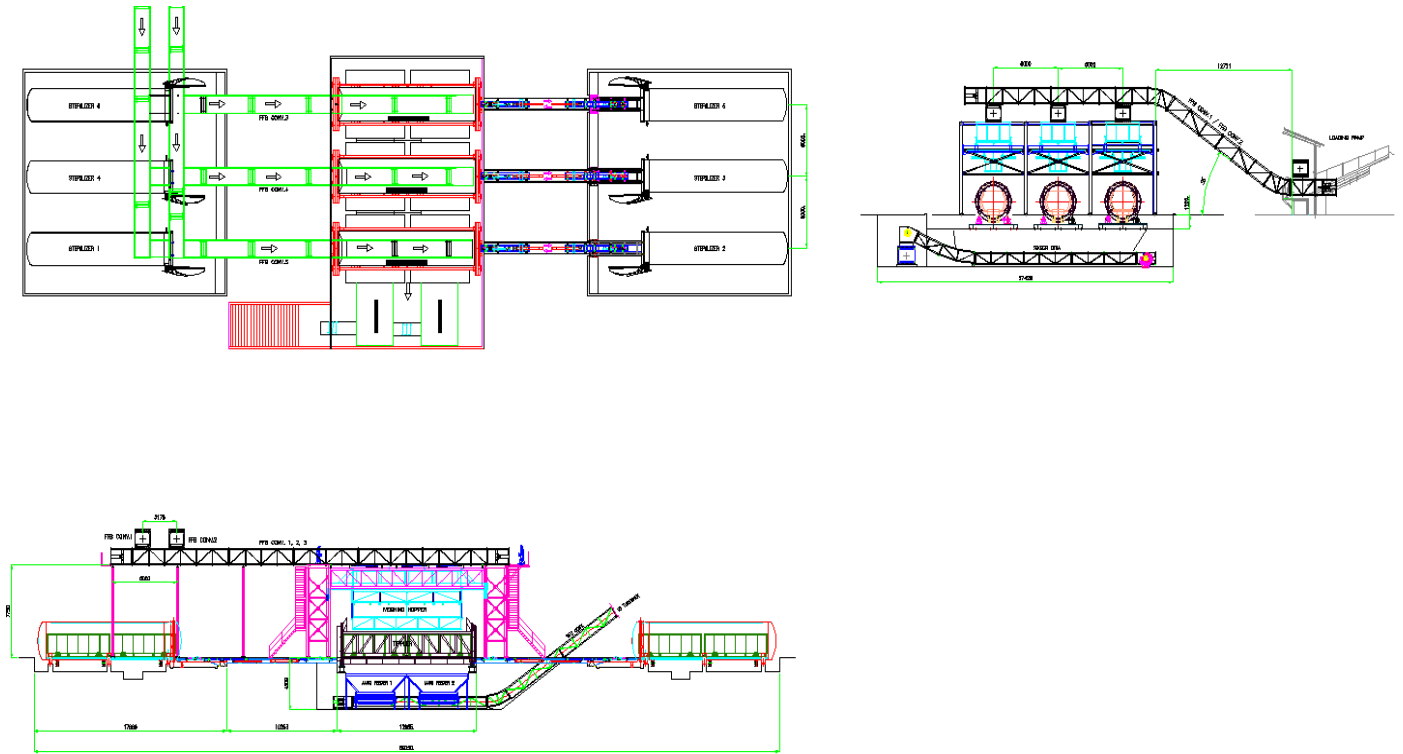

Control Grouping of CMC 60tph (Modular 4 x 30ton Sterilizer)

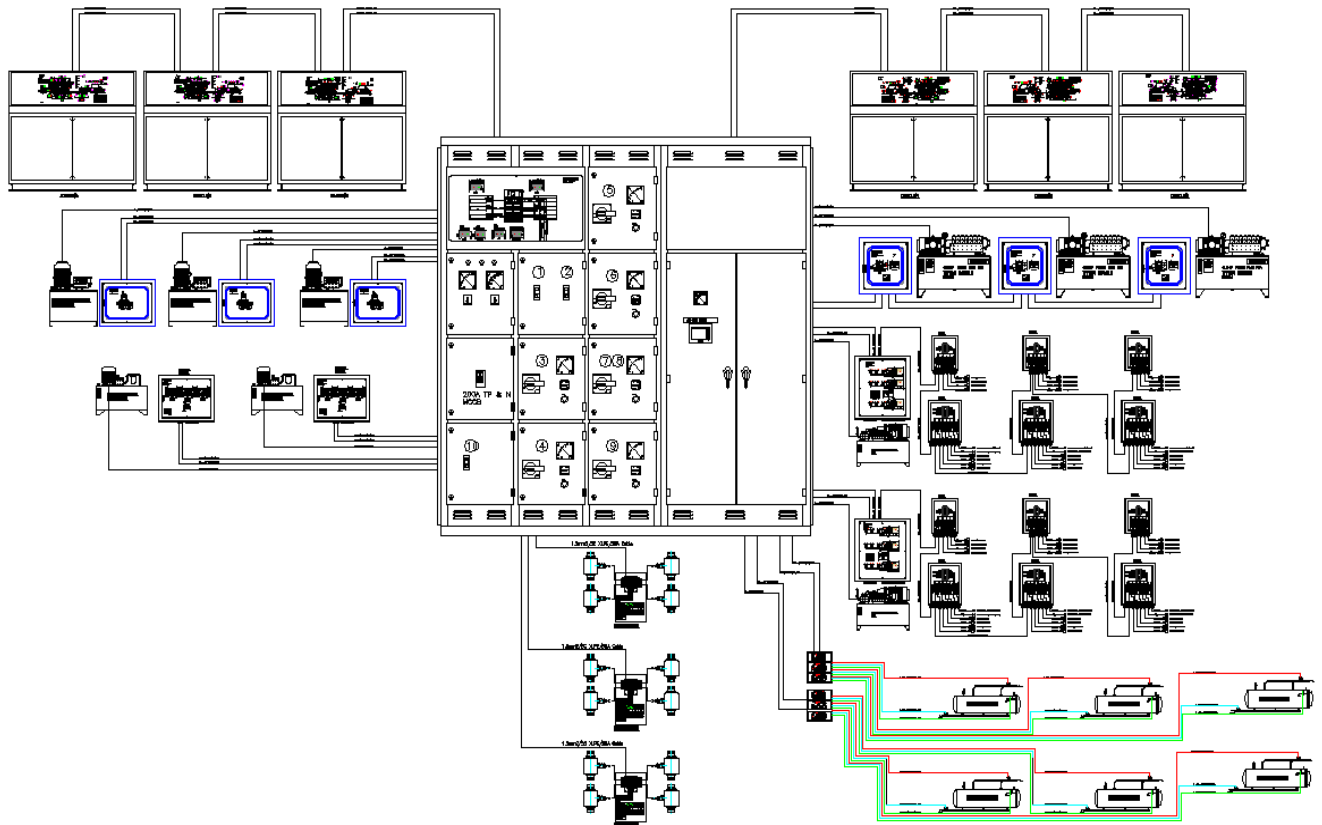

FFB Loading Ramp Hopper & Empty Bunch Hopper

Loading Ramp Hopper on fruit reception area on a sloping ramp not less than 27 degree slope c/w hydraulic operated doors are used to receive, store and load fresh fruit bunches to feeding point and are sized to suit the mill capacity planned to operated a day. One bay of loading ramp typically could hold 27 to 30mt of Fresh Fruit Bunches.

Grading can be done anywhere inside the premises of the mill or its agent. Normally, it is best done on a platform beside the loading ramp.

Empty Bunch Hopper at the storage point for empty fruit bunches Depending on the topography of the loading ramp area and feeding to cages, loading ramp have lately undergoing some changes as following:

- Horizontal Sterilizer mill: Either direct feeding in to train of Cages (Winches: undertow link chain or undertow conveyors) OR using Scrapper Bar Conveyor to a feeding point (Indexing Systems or CMC Systems as material handling) as Cage movement handling
- Non Horizontal Sterilizer mill: Using Scrapper Bar conveyor

For direct feeding in to Cages, loading ramp storage area is typically a long straight line to a feeding area. Using scrapper bar conveyors to a feeding point, loading ramp could be straight line, U-Shape or L-Shape. As such this is changing the elevation of loading ramp height as via the inclination of scrapper bar conveyor, loading ramp with scrapper bar conveyor could be same height as sterilizer station area.

Hydraulic system used in this application required a hydraulic power unit (HPU) located on the catwalk or raised platform to control a number of hopper doors, either in single or twin systems HPU.



Conveyor Sliding Hopper Door and Moving Chute and/or Telescopic Chute

For Sterilizer Station that is using Scrapper Bar Conveyor to a feeding point, where there's different types of Hopper Door and Chute to facilitate proper feeding.

Hydraulics Cylinder to operate various chutes could be combined into a few grouping of control valve to operate either directly via manual control valve or remotely via solenoid operated control valve.

- Horizontal Sterilizer mill using Scrapper Bar Conveyor via Sliding Hopper Door to Cage or Y-Chute to a Storage Hopper or to Cage
- Non Horizontal Sterilizer mill using Scrapper Bar Conveyor via Sliding Hopper Door, Moving Chute or Telescopic Chute on Non Horizontal Sterilizer mill design for fruit feeding purpose.

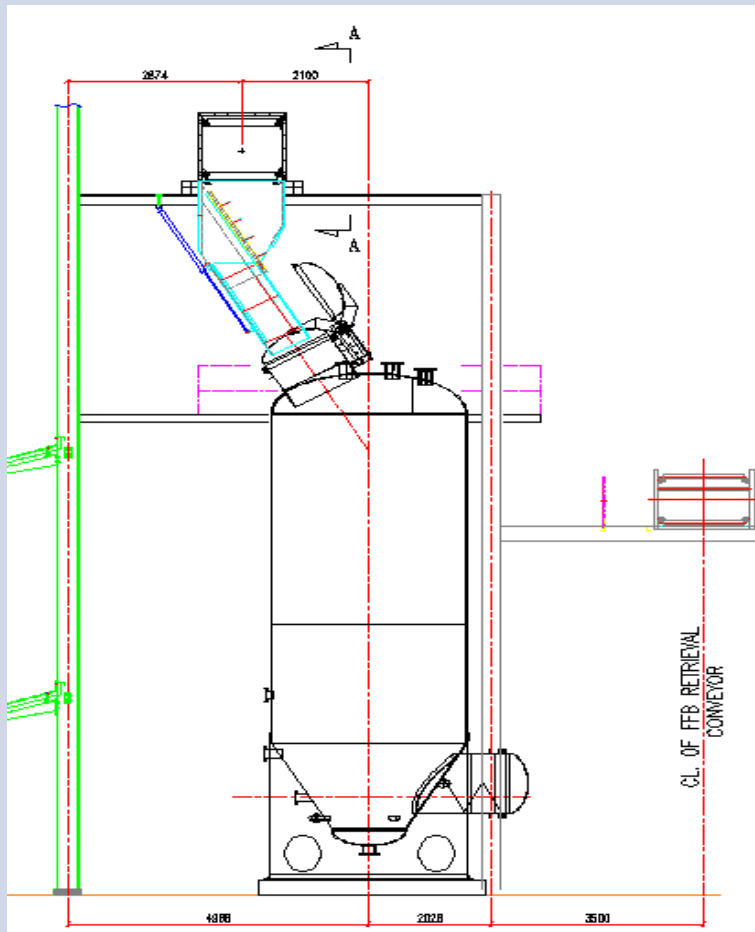

Cage Tipper or Mobile Tipper

Cage Tipper is designed to suit the robustness of use while maintaining cost effectiveness and to meet customer requirement of continuous production.

Either Cage Tipper size used in horizontal sterilizer mill with diameter of 2100mm; 2700mm; 2800mm to maximum of 3200mm Cage Diameter for:

- Single Cage Tipping for 5ton; 5ton; 7.5ton;10ton; 15ton to 17.5ton – using Winch; or Undertow Link-Chain; Undertow Conveyor or Indexing Systems
- Double Cage Tipping for 2x10ton; 2x15ton using CMC Systems

The main advantage of hydraulic driven Tipper is on the following:

- Hi-performance compact High Torque Low Speed radial piston motor specially designed for palm oil industry
- This is a **two-speed control** design that will allow high and low speed tipping and low speed for final rail track adjustment
- Built in **safety relief** and **counterbalance valve** in the hydraulic drive to prevent tipper drum creeping and better and more accurate holding and also tipping capability
- Minimum recommended ratio from Tipper Drum to Drive Sprocket is 8x
- HPU is sized up for maximum line pull force with extra safety factor of 1.5x

Hydraulic system used in this application required a hydraulic power unit (HPU) to drive the movement of Cage Tipper by controlling the actuators speed. The movement could be forward and reverse. Final drum rotation from hi-speed to low –speed range from 1.5 to 0.05 rpm, respectively. The system could be customized to suit the requirement

- **Controls:** Solenoid operated with dual speed capability, which is then controlled by electrical joystick via a floor stand control panel or PLC panel. Using of PLC allow automatic and manual operation

Option of Automatic Tipper Control is available as following:

- Regulated fruit cage tipping onto the existing auto-feeder /conveyor to avoid heaping of auto-feeder that in return overloads the downstream conveyors and thresher.
- Tipping process is controllable and regulated (programmable during setup for the best tipping process) for each tipping cycle and throughput is enhanced. The tipper speed is programmable for a fast, slow and even halt during tipping.
- Improved threshing and feeds of fruit will enhance digester /press efficiency

Mobile Tipper hydraulics system is sized up with additional Travelling and locking mechanism and safety interlock to suit different layout of horizontal sterilizer mill that is combining Tipper and Transfer Carriage.

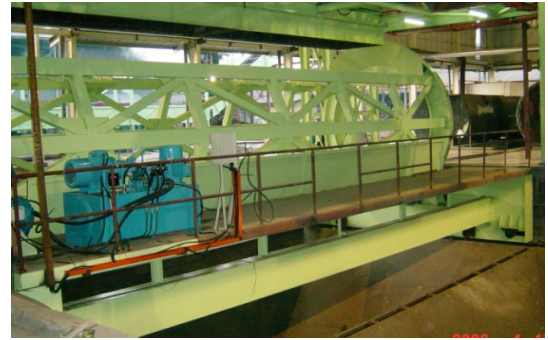

Sterilized Fruit Bunches Hopper Sliding Door as Auto-feeding

Sterilized Fruit Bunches Hopper is sized up to accommodate Tipper capacity per hour tipping (based on cage size used) and volume of SFB Hopper is designed to utilize a sliding Hopper Door on SFB Hopper to regulate as Auto-feeder. Sizing of SFB Hopper Sliding Door is to suit the width of SFB Conveyor used for throughput planned for the mill.

The main advantage of hydraulic driven SFB Hopper Sliding Door as Auto-feeding:

- Low cost construction and sliding door opening and closing is controlled via hydraulic regenerative system to allow balance and regulated feeding via SFB Conveyor
- Regulated SFB shall prevent heaping and bottleneck in SFB Conveyors thus allowing smoother flow process

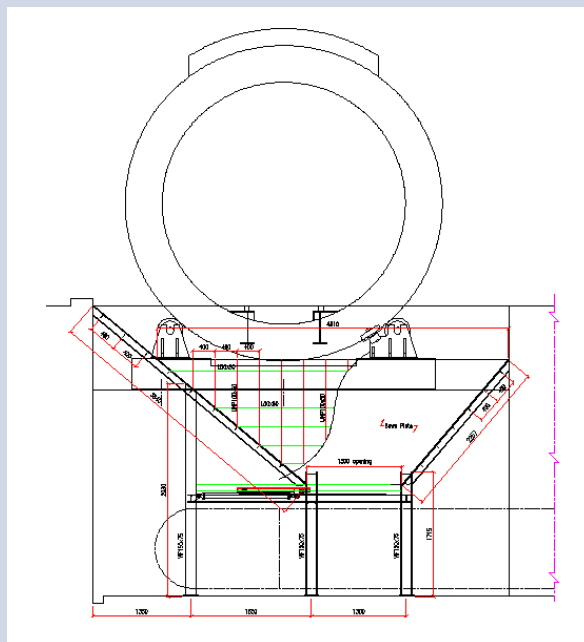
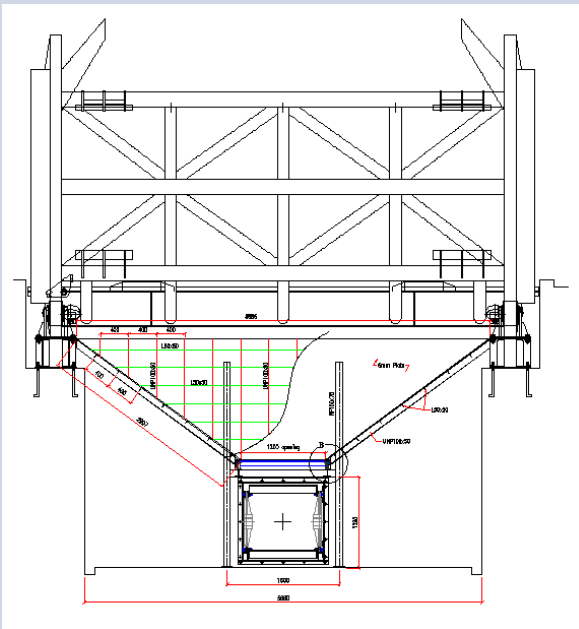
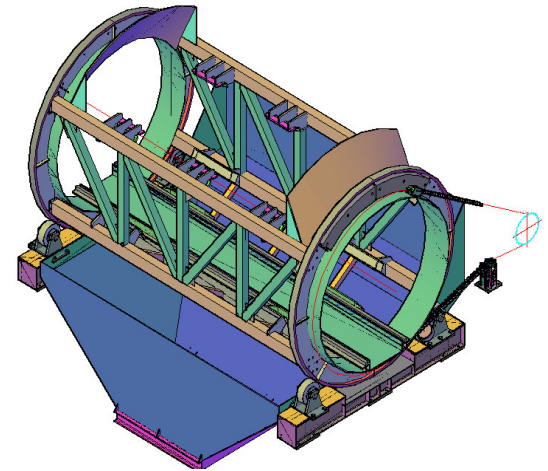

FFB and SFB Conveyor – Hydraulic Drive

Hydraulics driven conveyor drive system is designed to suit the robustness of use while maintaining cost effectiveness and to meet customer requirement of continuous production.

Hydraulic drive for Conveyor systems has been chosen lately over electro-gear motor due to hydraulic high starting torque compared to gear-motor that is helping to prolong the life span of conveyor chain used.

The key advantageous of using hydraulic drive comparing to electrical-gearbox (or gear-motor) as following:

- High power density / high starting torque capability. Conveyor applications in palm oil industries would require numerous time of start/stop. There would be shock exerted on the conveyor chain used. Using hydraulic drive with higher starting torque would prolong the lifespan of conveyor chain
- High overall efficiency. 90% volumetric efficiency, standardization of piston variable pump with efficient pump control on hydraulics systems
- Variable speed capability, from dual speed up to **proportional 6 speeds*** (Eaton original design--- using proportional valve)
- Manual Control, **interlocked & synchronized Control** and **Remote Monitor & Control** option available
- Single or Twin Drive for any horizontal and/or incline conveyor
- Suiting Continuous run conveyor design accordingly

Other than Scrapper Bar Conveyor hydraulic drive, Eaton also provide hydraulic drive for **Elevator**; **Screw Conveyor**; CBC Conveyor etc.. in Power Transmission solutions. **Eaton Green Pak HPU is available for screw conveyor drive.**

Hydraulic system used in this application required a hydraulic power unit (HPU) to drive the linear movement of FFB / SFB Conveyor by controlling the actuator speed automatically and remotely. Hydraulic actuator is coupled inline with the driven gear. The movement could be forward and reverse as simple as reversing the flow to the actuator via push buttons. There is build in mechanism to sense the load and speed of conveyor, which the actuator would auto adjust accordingly. Final output speed range from minimum 3 rpm and up to 30rpm. The system could be customized to suit the requirement

Eaton Variable Frequency Drive with HMI Operator Interface available for complete Conveyor Drives Automation Systems. Eaton Max Series Inverter is also available for Non-Hydraulics application.

*** for Horizontal or Inclined application*

Option for smaller drive unit is available as well.

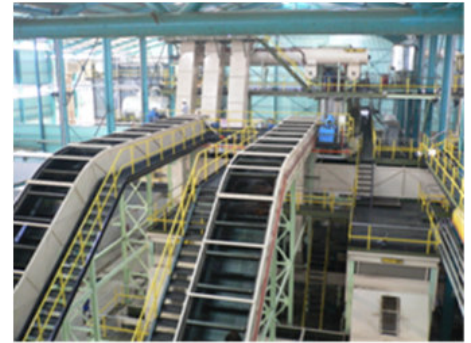

Transfer Carriage (with or without Cage Push Out mechanism)

Transfer carriage system is for variety of different cage sizes used in a typical palm oil mill. For cage size from 3.5ton; 5ton to 7.5ton are typically twin cage or triple cage per transfer carriage movement. For cage size of 10ton; 15ton to 17.5ton could use single cage or twin cage transfer carriage depending on the design of layout and proper calculation of time study.

A few different types of design of transfer carriage for cage push out:

- Tilting type transfer carriage (using two cylinder to jack up platform)
- Undertow type transfer carriage (using hydraulic motor to push out)
- Indexer type transfer carriage (using cylinder to push cage out)
- Empty type transfer carriage (cage charging and discharging of using Indexer mounted before each transfer carriage)

Transfer Carriage c/w Rotary Lock Hydraulic System is designed to provide a faster yet smoother cage transfer operation from one lane to another.

- Transfer carriage is positioned precisely without much adjustment as compare to latching cylinder used in earlier design
- Rotary Lock c/w bearings and other accessories provided driven by compact Hi Performance High Torque Low Speed
- Fully automatic locking and un-locking thus alignment of carriages
- Manual / Automatic available with Proximity sensors provided for inter-locking
- **Actuators used:**
 - Carriage traveling forward & reverse
 - Cage discharge: either hydraulic motor or hydraulic cylinder
 - Carriage alignment & latching: Hydraulic driven Rotary Lock is preferred now to two horizontally mounted tie-rod cylinders provide locking & latching of carriage

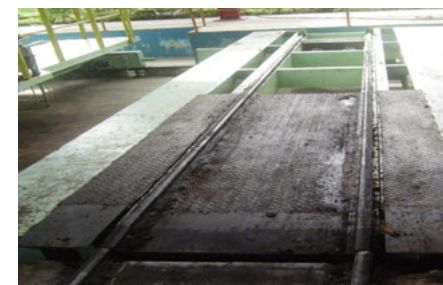
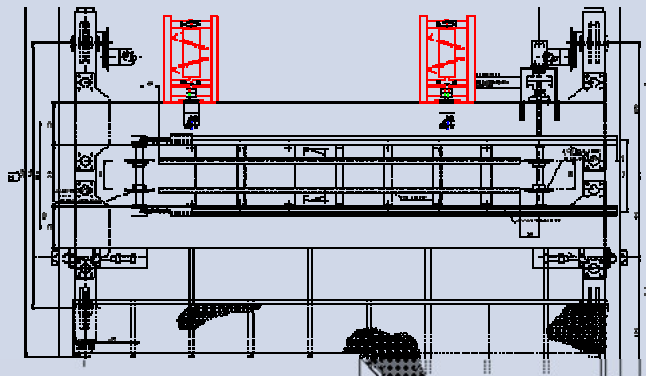

Tipping Platform

Tipping platform system is used on fruit loading ramp area for those non dump truck used to transport Fresh Fruit Bunches from estate to the mill.

Construction of length of Tipping Platform is to suit the overall length of truck used. Typical length of tipping platform ranges from 8meter, 12 meter to 15 meter for capacity range from 30ton to 70ton overall weight.

This Tipping Platform is as well for dumping Kernel transported by Truck to a Storage Point.

Hydraulic system used in this application required a hydraulic power unit (HPU) to drive two units of single acting double stage hydraulic cylinder that is mounted underneath a platform. Fast turn around cycle to unload the FFB from truck to loading bay. The system has infinite tipping angle to 30 degree. Customized system to suit your tipping requirement.

HPU: Electric motor sized up for maximum pushing force. Built-in over-load & over-torque protection adjustable safety relief valve incorporated within.

•**Controls:** Solenoid operated utilizing a lift lowering manifold block. Manual control is also available. Velocity fuse and safety valve incorporated within the system to prevent the platform sliding down

•**Actuator:**

For Site Pushing Platform; Two single acting single stage cylinders with female clevis on both-end to push up a platform sized to tipping capacity.

For Telescopic Tipping Platform: Two single acting double stage telescopic cylinders with tang mounting on both-end to push up a platform with approximate eight-meter length

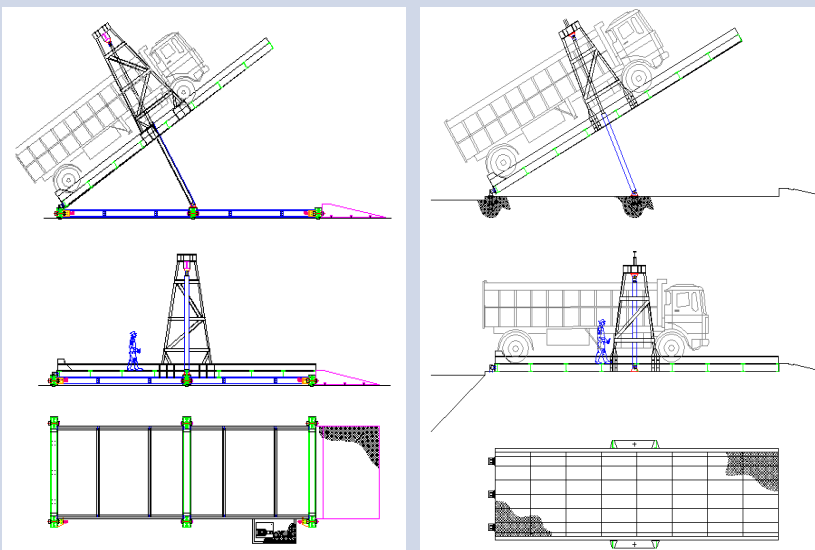

Compact Hydraulic Wire Rope Winch – for Horizontal Sterilizer mill

Wire rope winch system is specially design for palm oil horizontal line pull for position in between sterilizer rail track line. Our design is to suit the robustness of use while maintaining cost effectiveness and to meet customer requirement of safety in pulling.. Typically used for replacement of double drum capstan driven by electric motor gear-motor as well as for cage handling using winch design.

The main advantage of hydraulic driven winch is on the following:

- Cost effective with ready-to-use & easy-to-install package where scope of supply complete wire rope and hook; manual or solenoid control valve; starter panel for HPU, option of stainless steel (SUS) tubing or mild steel tubing
- Hi-performance High Torque Low Speed radial piston motor specially designed for palm oil industry with option of free-wheeling
- Option of variable winch speed if choosing solenoid directional control valve
- HPU is sized up for maximum line pull force with extra safety factor of 1.5x

These are the features not available in non –Eaton design winch:

- Width of Compact Winch Drum is standardized to less than one meter for all different sizes.
- Built-in over-load & over-torque protection adjustable pressure relief valve for preventing wire rope to snap
- Full drum reversal at maximum line speed capability. For maintaining wire rope in winch drum when not in used

The following Winch Drum capacity are made available for pulling a train of cages of different capacity (3.5ton / 5ton / 7.5 ton / 10ton / 15ton). Wire rope used is of 6x36 IWRC from $\phi 16\text{mm}$; $\phi 18\text{mm}$; $\phi 20\text{mm}$ to $\phi 22\text{mm}$.

- 3-ton line pull capacity for 40-tonf
- 4/5-ton line pull capacity for 75 to 90 ton
- 7-ton line pull capacity for 120tonf
- 10-ton line pull capacity for 150tonf
- 12-ton line pull capacity for 180tonf

Hydraulic system used in this application required a hydraulic power unit (HPU) to drive a high volumetric and mechanical efficiency high torque low speed hydraulic motor that is directly attached to a mechanical winch drum. The drum outer surface machined with grooves for easy wire rope pay-in and out. The movement could be forward and reverse via a manual control valve installed on top of the winch structure or mounted at an elevated platform.

Both Horizontal Wire Rope Winch and Vertical Capstan with Hydraulic Drive are available.

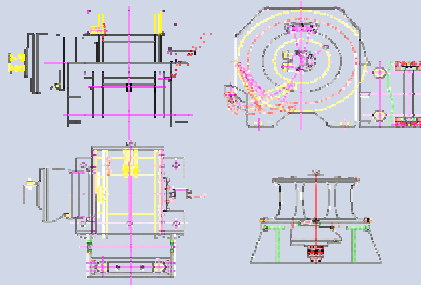

Undertow Conveyor for Cage Movement in Horizontal Sterilizer mill

Undertow conveyor system is designed to suit the robustness of use while maintaining cost effectiveness and to meet customer requirement of continuous production. The choice of quality components manufactured by Eaton provides higher uptime, increases system efficiency and reduces power losses due to low internal leakage. The system is easy to set-up and installation and also lower in maintenance

Hydraulic system used in this application required a hydraulic power unit (HPU) to drive the high torque low speed hydraulic motor that is directly attached to a sprocket of undertow conveyor chain mounted on a frame with tipping dogs to push the cage. The movement could be forward and reverse via the directional control valve. This cost effective system could be customized to suit the requirement

- **HPU:** Electric motor sized up for maximum system operating pressure at 250 bar. Built-in over-load & over-torque protection adjustable safety relief valve incorporated within. HPU is normally located near the actuator
- **Controls:** Smooth and reliable spool movement. Excellent inching operation by precision machined spool notches. Variable speed control. Installed on top of HPU
- **Actuator:** Field proven Vickers GM series radial piston motor fitted with planetary reducer. Hydraulic motor is of latest generation of high-torque low speed drive, providing high starting and running torque minimizing internal leakage. The combined output torque provided with a minimum safety factor of 150% (design pressure / max continuous pressure)

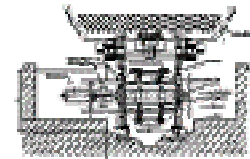

Horizontal Sterilizer Door

Sterilizer Door Hydraulics and Control System is designed to suit different type of horizontal sterilizer configuration. Our design for this system is with safety interlocked between the operation of Sterilizer Doors and Sterilizer Automation.

Typical customization to suit any sterilizer door in the market for 2100mm, 2700mm ; 2800mm and 3200mm O.D. Hydraulic cylinders supplied are used for door opening/closing with lock/unlocking to suit different door size.

Hydraulic system used in this application required a hydraulic power unit (HPU), located on the platform or next to each end of Sterilizer Pit and cylinders to perform the door open/close movement and lock/unlock mechanism.

Eaton's PLC controlled safety interlocked for Sterilizer Doors

The door CANNOT open or UNLOCK when the followings conditions are not met

- The sterilization cycle is in progress [interlock signal from Sterilizer Automation Panel]
- The pressure within the Sterilizer is ABOVE the Preset low / safe pressure (above 0.3 psi)
- Only after above conditions are met, or via an alternative visual warning to user before the safe operation of door opening sequence.
- Either door open using manual or automatic mode, the tell tale valve (actuator on tell tale valve) is pre-activated to open.
- Door unlocking operation is not possible if tell tale valve is not fully opened
- Door can only be opened only when the locking cylinder is fully unlocked
- Door is in fully close operation, the locking cylinder is enabled

In addition to flexibility and performance, our design is based on the following criteria:

- Use at extreme operating temperatures.
- Safety under extreme mechanical stress caused by impacts and shocks
- Use even with direct exposure to dirt, water and humidity.
- Operational reliability despite strong supply voltage fluctuation in the electrical system
- Insensitivity to conducted and radiated interference in the whole electrical system.

To open the Sterilizer door:

1. The hydraulic power unit motor must be running in normal mode
2. Sterilizer Door is closed and locked
3. Sterilizer is on **LOW PRESSURE**
(*Pressure transmitter must be installed, and Safe Setting must below 0.3Psi*)

To Close the Sterilizer door:

1. The electric motor on HPU must be running in normal mode
2. Sterilizer Door is opened and unlocked
3. The Chute is at Close position

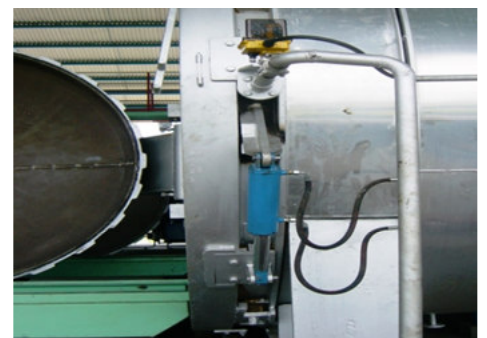

Eaton Sterilizer Doors (with / without Drawbridges) Control Schematics

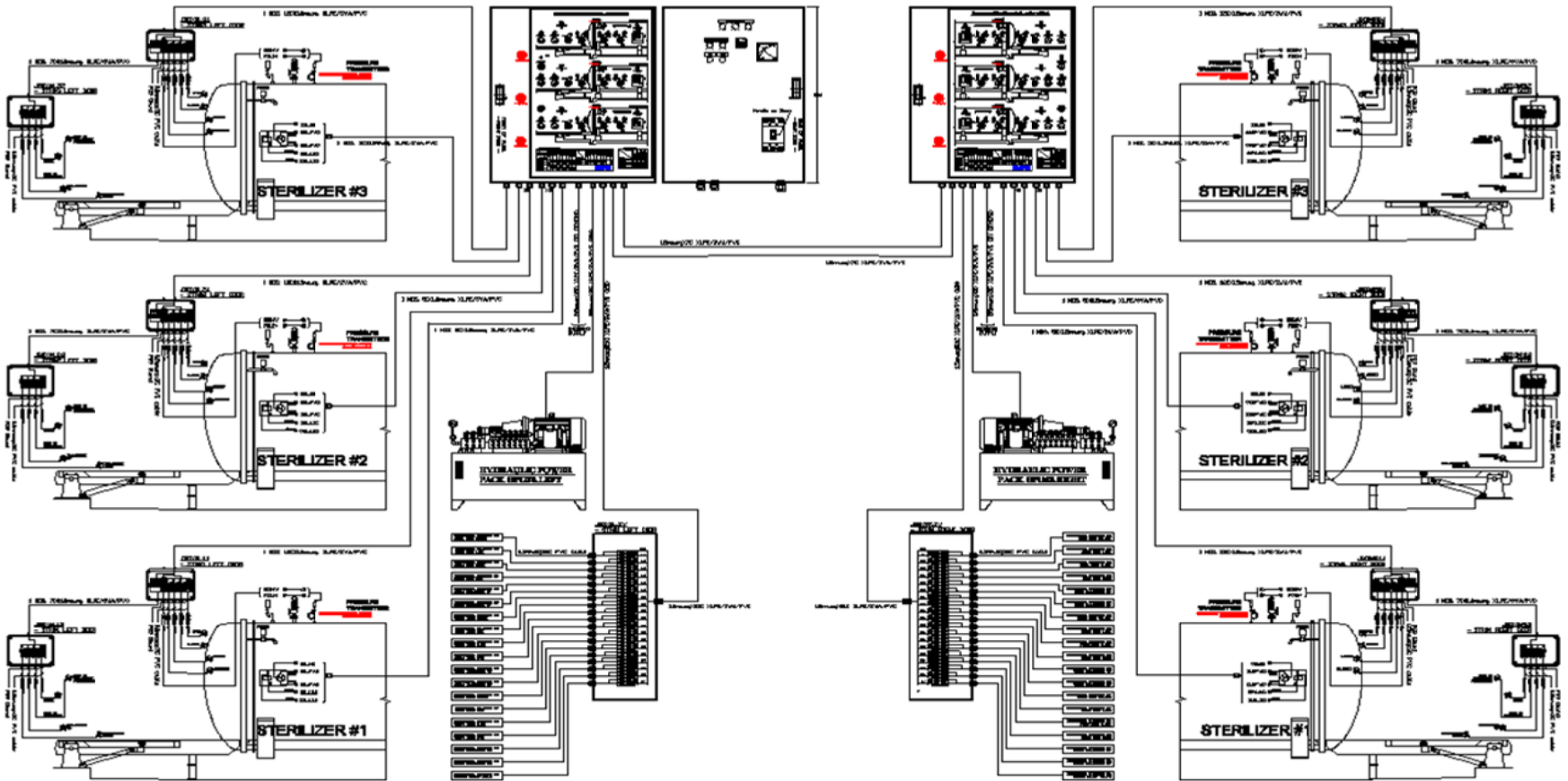
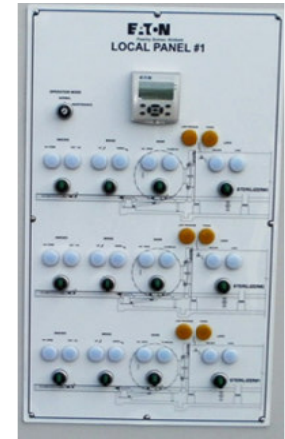

Cantilever Drawbridge

Cantilever drawbridge is mostly used now in horizontal sterilizer to bridge the sterilizer pit between sterilizer rail track line to Sterilizer. It is at 95 degree typically when drawbridge structure is raised up to allow any Door size to open smoothly.

Typical customization to suit any sterilizer door in the market for 2100mm, 2700mm ; 2800mm and 3200mm O.D to suit different size of cage used from 3.5ton; 5ton; 7.5ton;10ton; 15ton to 17.5ton.

The main advantage of hydraulic operated cantilever drawbridge, instead of manual mobile trolley (moved by operator) is on the following:

- Safety for operator, where do not require to go down to sterilizer pit to move the mobile trolley manually
- Cost effective with ready-to-use & easy-to-install package where scope of supply complete gypsy head and drive structure at drive end; tensioner structure and gypsy at driven end; undertow trolley; link chain of 16mm; manual or solenoid control valve; starter panel for HPU, option of stainless steel (SUS) tubing or mild steel tubing for HPU to drive unit
- Hi-performance High Torque Low Speed hydraulic cylinder with option of stainless steel rod used in Wet End Area
- Safety valve incorporated in to prevent drawbridge going down unnecessary
- HPU is sized up for maximum line pull force with extra safety factor of 1.5x

Hydraulic system used in this application required a hydraulic power unit (HPU), located on the platform, and actuators such as cylinders to perform the door open/close movement and lock/unlock mechanism.

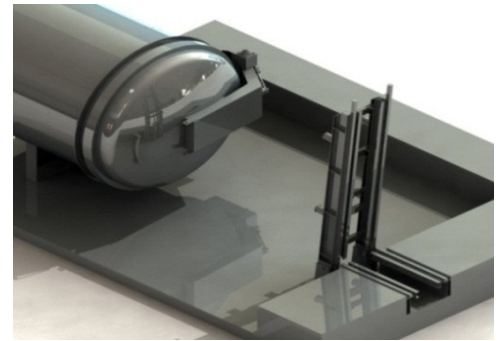
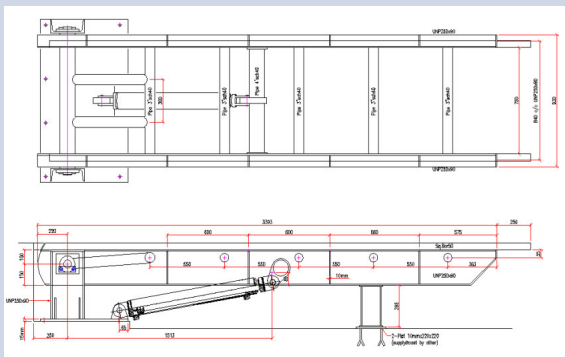
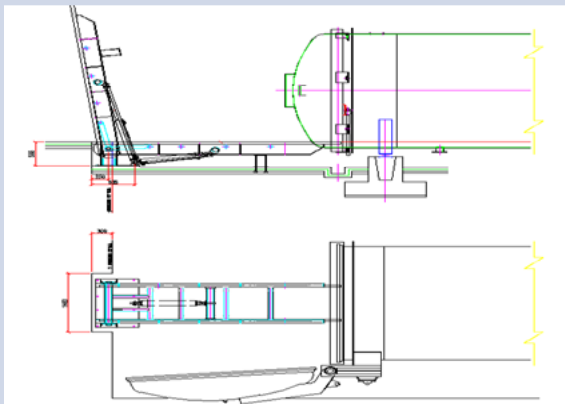



Eaton Automation Control in Steam Utilization

From
Lean Connectivity
to
Lean Automation

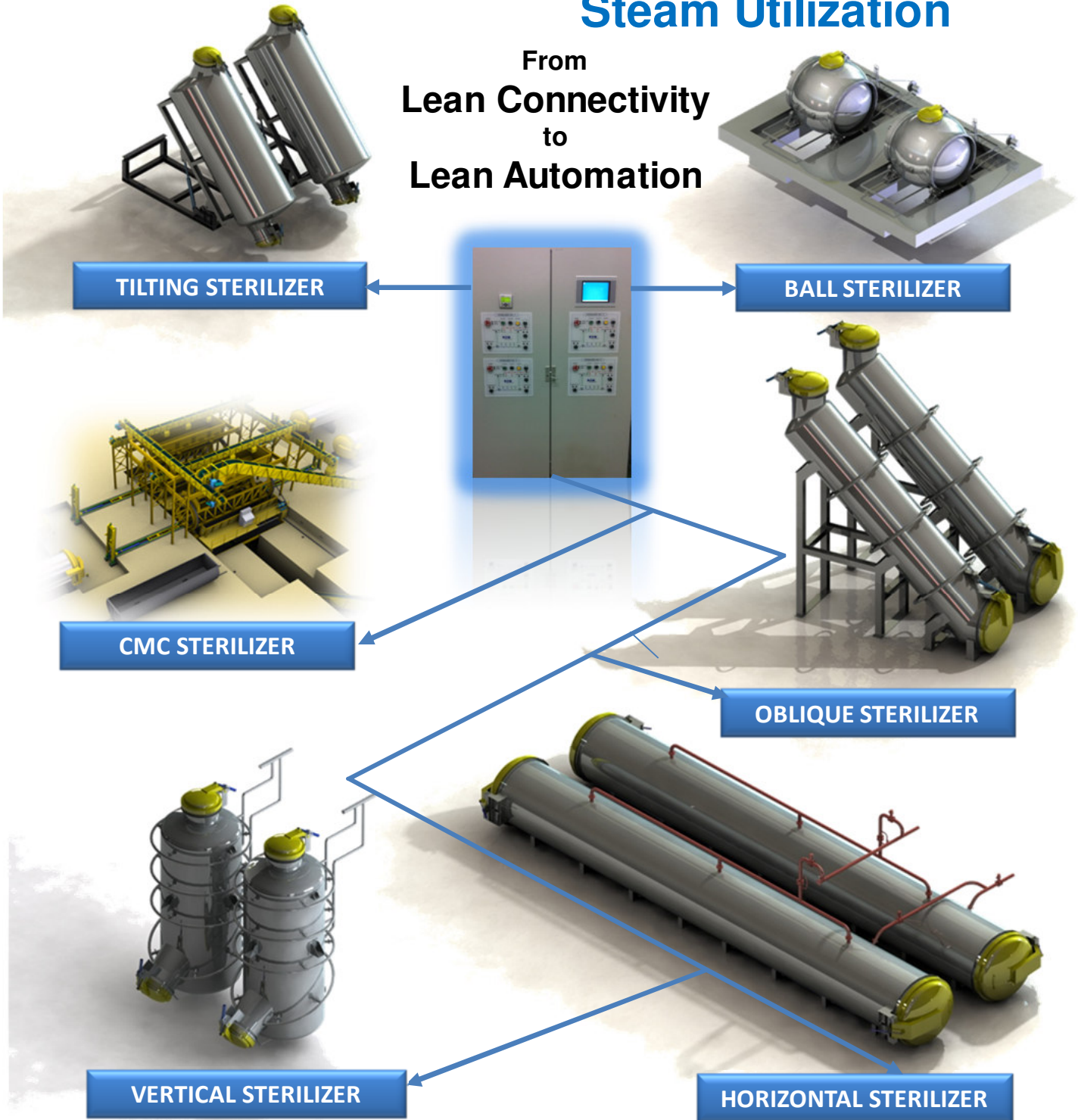

Sterilization Process (Typical 3 peaks for Horizontal Sterilizer)

The choices in the sterilization process selections could make easy with the general guidelines on the basic fundamental for sterilization as below:

The challenge in Sterilization process is to maintain a balance of:

- Cooking the fruit bunches in the sterilizer yet to preserve the encrusted membrane intact. Else,
- Over-cooking shall damage the oil encrusted membrane. Oil will squeeze out from fruitlets and absorb into the empty bunch which is costly to extract.

To allow a synchronized integration, the sterilization process is preferably using 3(Three) peak process but confines to only the following

- The first peak is time based to enable a pre-heating process of the FFB
- The discharge of condensate and air in the pressure vessel after the 1st peak is on time base with a single de-aeration without getting the pressure down to almost atmospheric pressure in the conventional process. The time shall be long enough to drive all condensate and most of the air in the sterilizer out to the blow down chamber
- The second peak built-up is similar to the 1st peak, but the pressure will definitely build to a higher pressure than the first peak (the duration is same as 1st peak). As the pressure vessel is getting hotter less condensation will take place and the pressure is built faster than before
- Discharging of condensate after the second peak will be similar to item 1st peak de-aeration
- The third peak and the hold cycle is mainly the thorough cooking process where FFB are cooked under pressure with more evenly distributed steam (more even temperature) in the pressure vessel.

The process save the precious time and possibly the steam during the sterilization process than the conventional practice where substantial waiting time is wasted on building every peak to its maximum pressure and exhausts to almost the atmospheric pressure in exhaust / drain cycle where in between no effective function/work is done.

Sterilization time of 55 ~ 60 minutes (on door closing and opening) is common in the upgraded process. **This allows perfect synchronization to the time and motion analysis.**

*Eaton Hardware for Automation is catered for **4 x Sterilizers**, where software and logic diagram inside the Industrial PC and PLC is more than sufficient for future expansion, if any.*

Special feature: **Condensates are continuously discharged to improve efficiency of sterilization during holding state by programmed PID (Proportional, Integral and Derivative) within Steam Inlet and Condensate Valve.**

Sterilizer Auto Control Panel is designed based on Time and Pressure of valves sequencing.

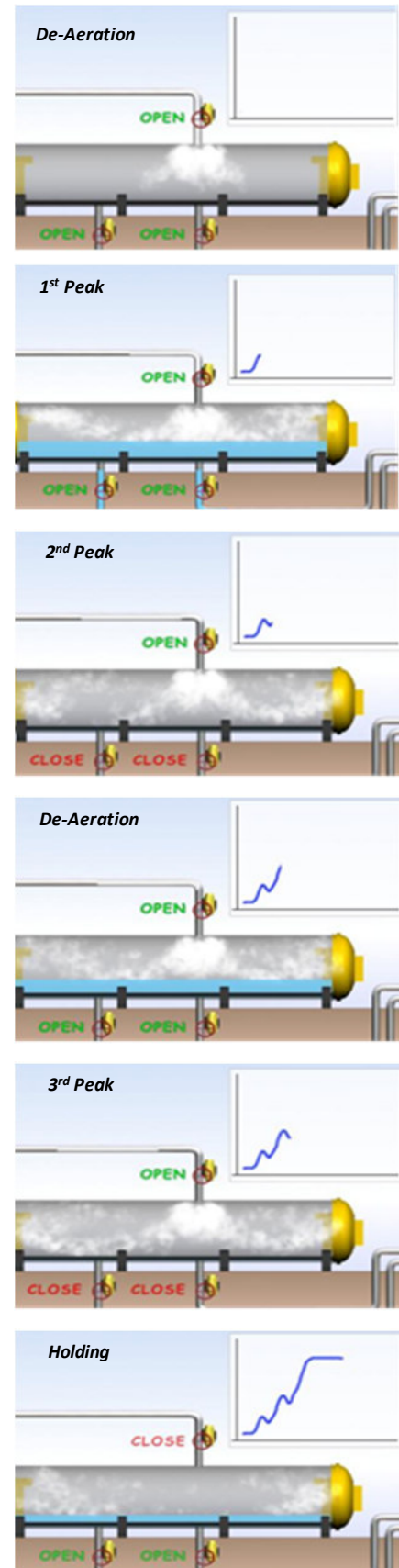

Horizontal Sterilizer Auto Controller

One Eaton (Hardware and Software)

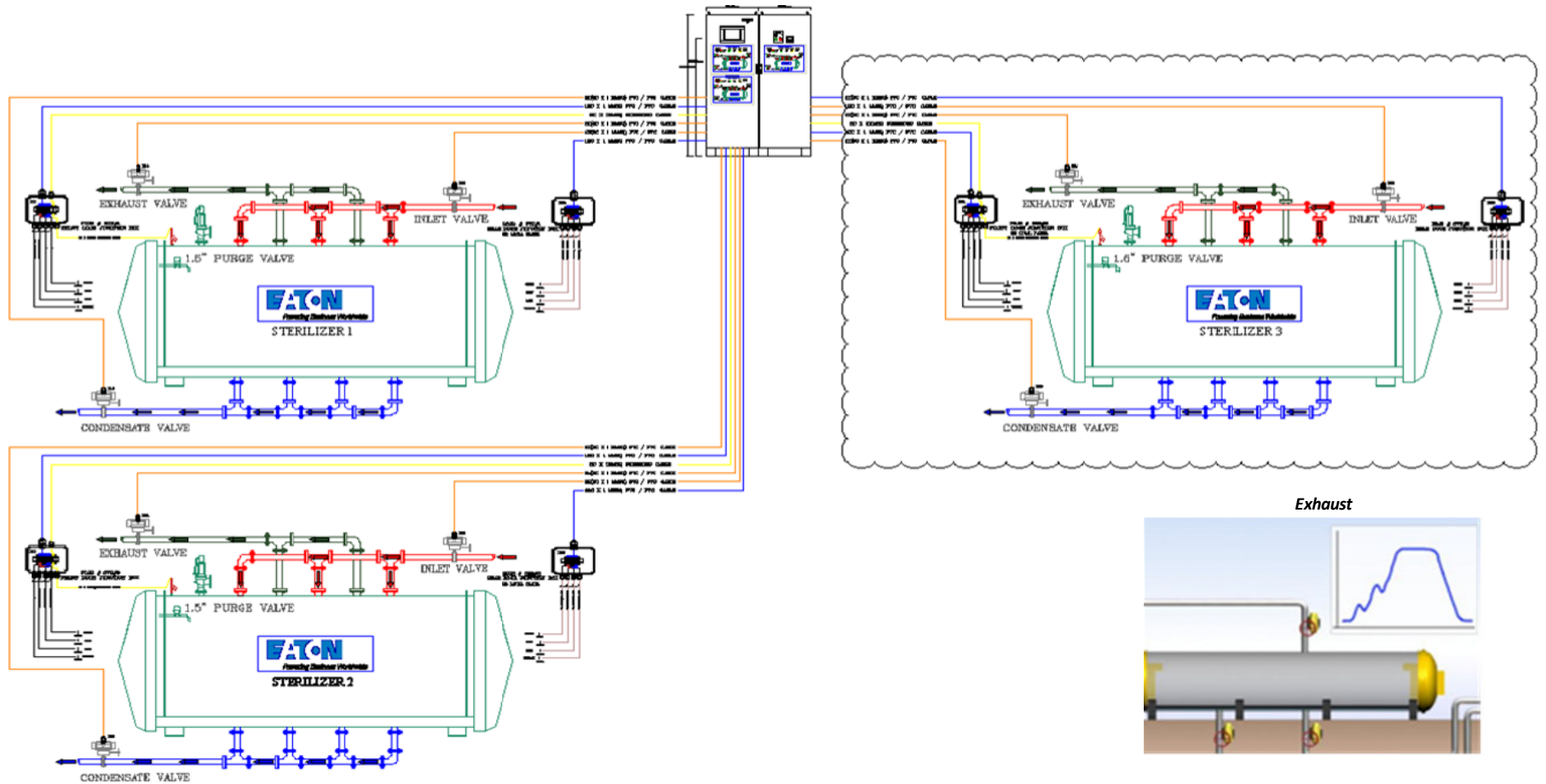

Grouping 2 x Horizontal Sterilizers with 3 Steam Valves (extendable up to 4 Sterilizers)

Vertical Sterilizer - Hydraulics Systems and Interlocked Process Control

Vertical Sterilizers have an effective capacity ranging from 15t to 20t FFB. They are customized cylindrical steel vessels, made of boiler grade materials, fully welded and sized to suit the capacity needed. Latest generation of Vertical Sterilizer does not use water. Bottom Door could be horizontal or Sloping Chute Door.

There are a few different model of Vertical Sterilizer by different Sterilizer manufacturer which are using different Valves per Sterilizer:

- 3 Steam Valves (Inlet; Exhaust; Condensate)
- 4 Steam Valves (Main Inlet; Aux Inlet, Exhaust; Condensate)
- 5 Steam Valves (Main Inlet; Aux Inlet, Exhaust; Condensate; Condensate By Pass)
- 6 Steam Valves (Main Inlet; Aux Inlet 1; Aux Inlet 2; Venting, Exhaust; Condensate; Condensate By Pass)
- 7 Steam Valves (Main Inlet; Aux Inlet 1; Aux Inlet 2; Aux Inlet 3, Exhaust; Condensate; Condensate By Pass)

Various sterilizer clutched door used: 900-950mm; 1100mm; 1200mm, 2100mm, 2700mm and 3200mm O.D. Hydraulic cylinders supplied are used for door opening/closing with lock/unlocking device. Auger is either internal or external type.

Eaton Sterilizer Automation Control interlocked with Sterilizer Door Control system for:

- Operating mode: Automated (via start button by PLC); Semi-Auto (via on/off switches on work station); Manual By-pass (using manual override system)
- Provision for sterilizers to operate individually or synchronized to permit sequential operation of all sterilizers
- Safety devices and interlock fully complied to industrial safety requirement
- Flexible control system with unlimited combination of operation pattern for peak, de-aeration, exhaust, etc. via various valves sequencing

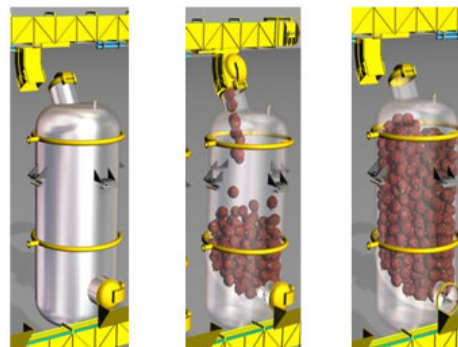
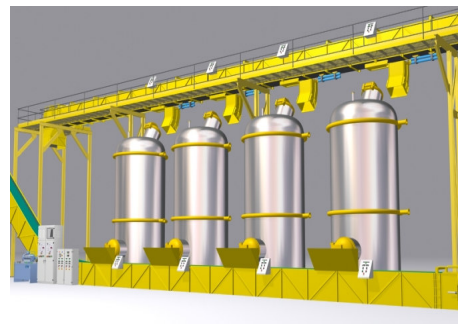

	Sterilizer Low Pressure (<1 Bar)	PX-Chute-Open	PX-Chute-Close	PX-Chute-home	PX-Chute-feed	PX-Top Door-open	PX-Top Door-Lock	PX-Top Door-Unlock	PX-Top Door-Close	PX-Top Door-Lock	PX-Bottom Door-open	PX-Bottom Door-Lock	PX-Bottom Door-Unlock	PX-Bottom Door-Close	PX-Bottom Door-Lock	Process
SteamInletValveOpenRelay	1								1	1				1	1	Safety Interlock
Top DoorUnlockRelay	1			1	0											SFB Discharge
Top DoorOpenRelay	1			1	0			1								
Bottom DoorUnlockRelay	1			1	0											
Bottom DoorOpenRelay	1	1		1	0	1	1									
Auger StartRelay											1	1	0	0		FFB Feeding
Bottom DoorCloseRelay	1													1		
Bottom DoorLockRelay														1		
MovingChutePositionFeedRelay	1					1	1	0	0	0	0	0	1	1		Initiate Cooking
HopperDoor-OpenRelay	1			1												
HopperDoor-CloseRelay	1															
MovingChutePositionHomeRelay	1	1														
Top DoorCloseRelay	1		1	0												
Top DoorLockRelay	1		1	0				1								

Eaton design of safety interlocking, controlled by PLC:

Sterilizer manufacturer:

- In Indonesia: PT.TriRoyal TimurRaya; PT.EraCipta BinaKarya; PT.Duta Marga Lestarindo, etc..
- In Malaysia : Kejuruteraan Wang Yuen Sdn Bhd; Cidar Engineering Sdn Bhd; CHD IP Technology Sdn Bhd, etc..

Vertical Sterilizer Auto Controller

One Eaton (Hardware and Software)

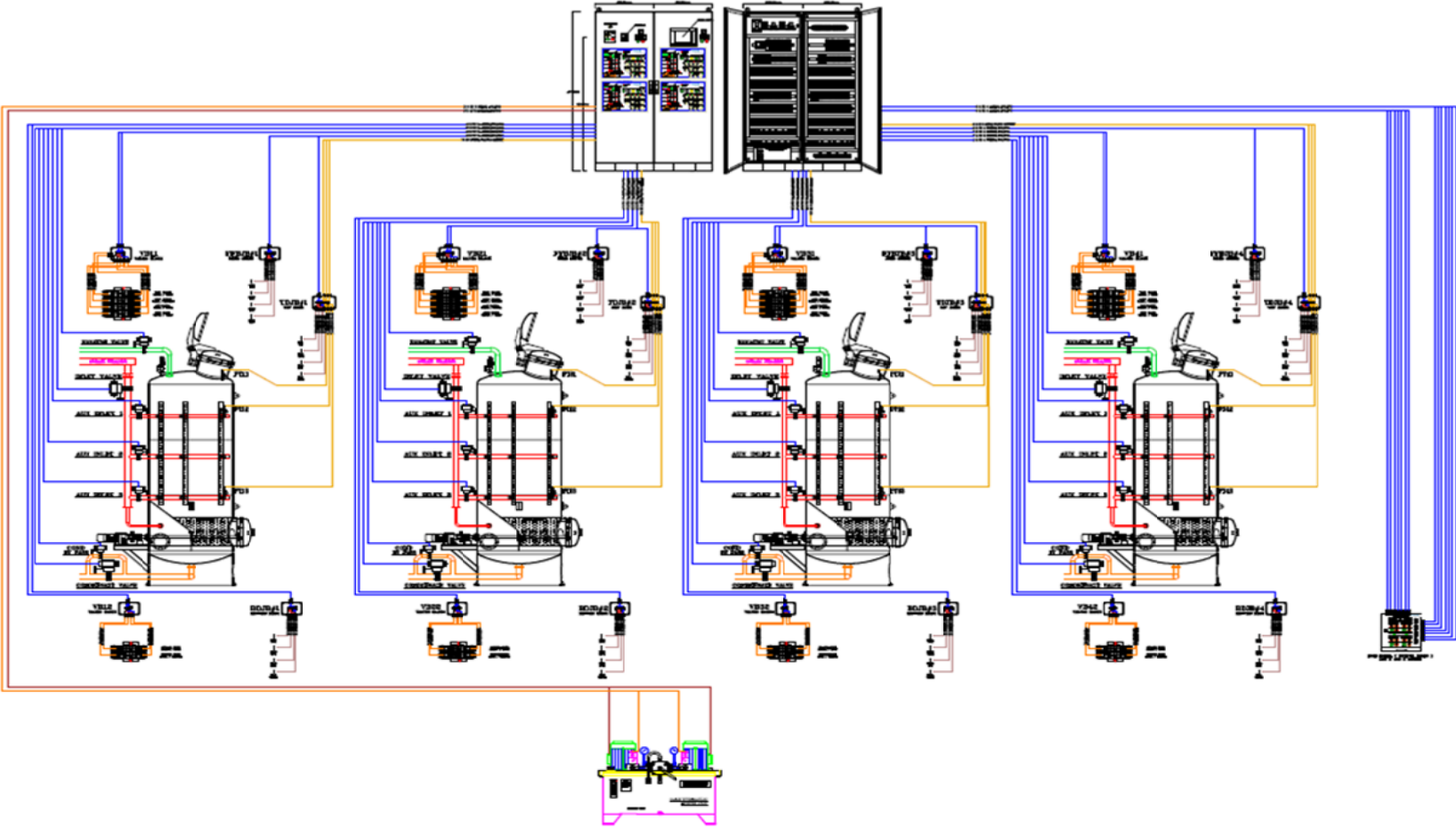

Grouping 4 x Vertical Sterilizers with 7 Steam Valves and Electric Motor Internal Auger

Oblique Sterilizer - Hydraulics Systems and Interlocked Process Control

Oblique Sterilizer is mounted at fixed structure of 45 degree inclination to distribute evenly the lessen the impact of gravitational force. Top Sterilizer Door is 1200mm, while Bottom Sterilizer Door is 2100mm. Sterilizer Capacity is 20ton.

A	Steam Inlet Valve	1
	6" OKM 54TP High Performance Butterfly Valve with Teflon Seat c/w Pneumatic Single Acting Actuator with Declutchable Manual Override Handwheel and Mounting Bracket & Adaptor with matching flanges, bolts, nuts, washer and Gasket	
B	Steam Inlet Auxiliary Valve	3
	4" OKM 54TP High Performance Butterfly Valve with Teflon Seat c/w Pneumatic Single Acting Actuator with Declutchable Manual Override Handwheel and Mounting Bracket & Adaptor with matching flanges, bolts, nuts, washer and Gasket. c/w Limit Switch (On/Off Signal)	
C	Exhaust Valve	1
	6" OKM 54TP High Performance Butterfly Valve with Teflon Seat c/w Pneumatic Single Acting Actuator with Declutchable Manual Override Handwheel and Mounting Bracket & Adaptor with matching flanges, bolts, nuts, washer and Gasket	
D	Condensate Valve	1
	8" OKM 54MP High Performance Butterfly Valve with Metal Seat c/w Pneumatic Single Acting Actuator with Declutchable Manual Override Handwheel and Mounting Bracket & Adaptor with matching flanges, bolts, nuts, washer and Gasket	
E	Condensate By Pass Valve	1
	2" 3pcs Body Ball Stainless steel 316 ball valve with BSPT, threaded end and ISO 5211 Mounting Pad c/w pneumatic double acting actuator	

Condensates are continuously discharged to improve efficiency of sterilization during holding state by programmed PID (Proportional, Integral and Derivative) within Steam Inlet and Condensate Valve.

Our program could suit a number of steam valves used, up-to combination of 7 valves per sterilizers. Please see sample below a typical combination of Steam Valves sequencing.

Oblique Sterilizer Valve Sequencing with 7 Valves										
Step	Time	ΣT	Inlet	Aux Inlet 1	Aux Inlet 2	Aux Inlet 3	Exhaust	Condensate	Cond By Pass	Remarks
1	01:00	01:00	X		X		X	X		DeAeration
2	08:00	09:00	X	X		X				1st Peak
3	01:00	10:00						X		Condensate
4	02:00	12:00					X	X		Exhaust + Cond
5	00:30	12:30	X		X		X	X		DeAeration
6	10:00	22:30	X	X		X				2nd Peak
7	01:00	23:30						X		Condensate
8	02:00	25:30					X	X		Exhaust + Cond
9	00:30	26:00	X		X		X	X		DeAeration
10	13:00	39:00	X	X		X				3rd Peak
11	00:30	39:30	S	S					X	Holding & Discharge Condensate
12	14:00	53:30	S	S		X				Holding
13	00:30	54:00	S	S					X	Holding & Discharge Condensate
14	14:00	68:00	S	S		X				Holding
15	03:00	71:00						X		Condensate
16	09:00	80:00					X	X	X	Exh + Cond + Vent

Sterilizer manufacturer:

- Oblique Sterilizer in Indonesia: PT.TriRoyal TimurRaya
- Slanted Sterilizer in Malaysia : Ecoscience Engineering Sdn Bhd



Oblique Sterilizer Auto Controller

One Eaton (Hardware and Software)

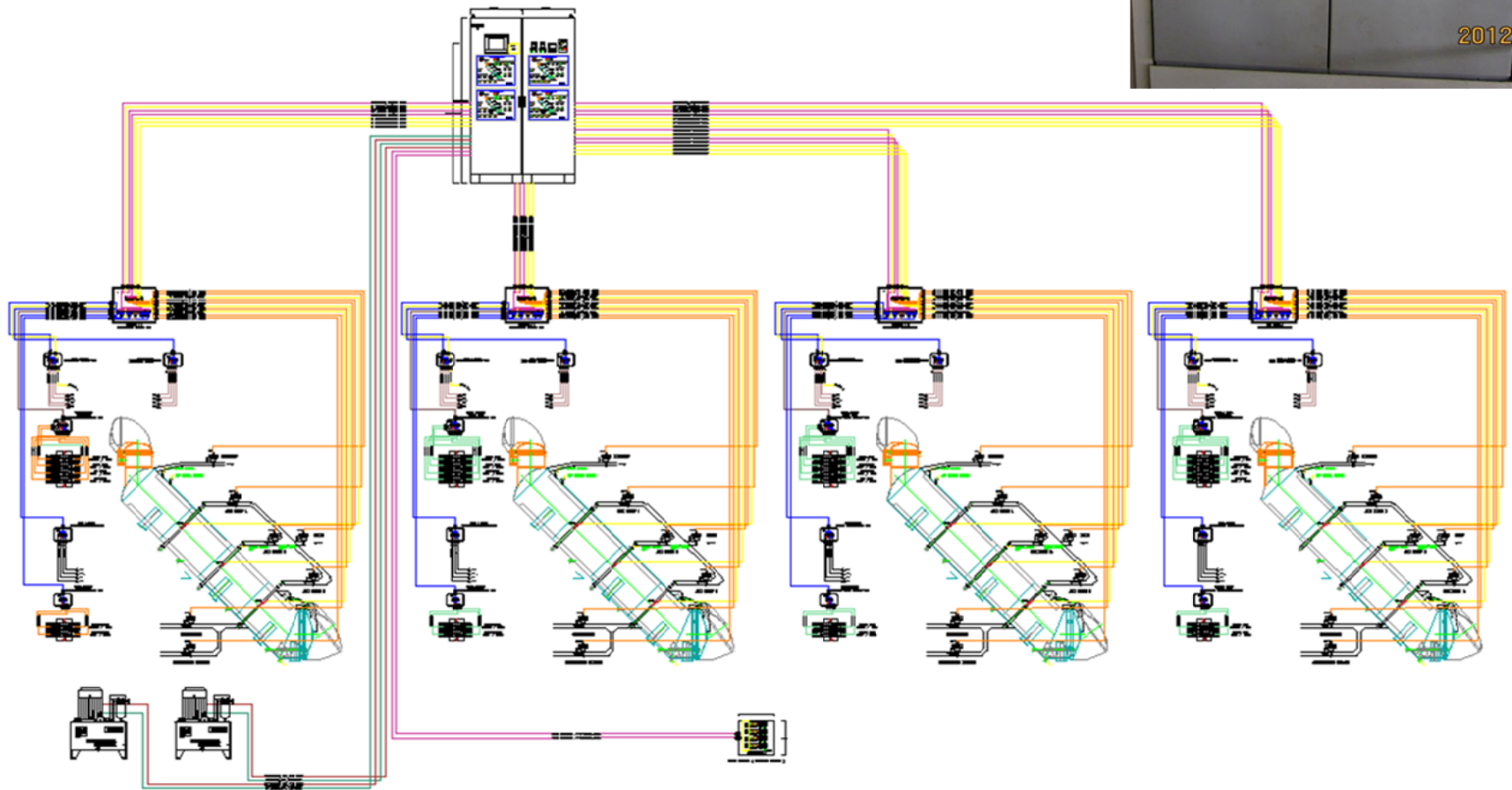

Grouping 4 x Oblique Sterilizers with 7 Steam Valves

Tilting Sterilizer - Hydraulics Systems and Interlocked Process Control

Tilting Sterilizer is mounted at base structure and resting a horizontal position during cooking and tilted up 45 to 50 degree inclination for discharging Sterilizer Fruit Bunches and filling. Top Sterilizer Door is 1200mm, while Bottom Sterilizer Door is 2100mm. Sterilizer Capacity is 25 to 30ton.

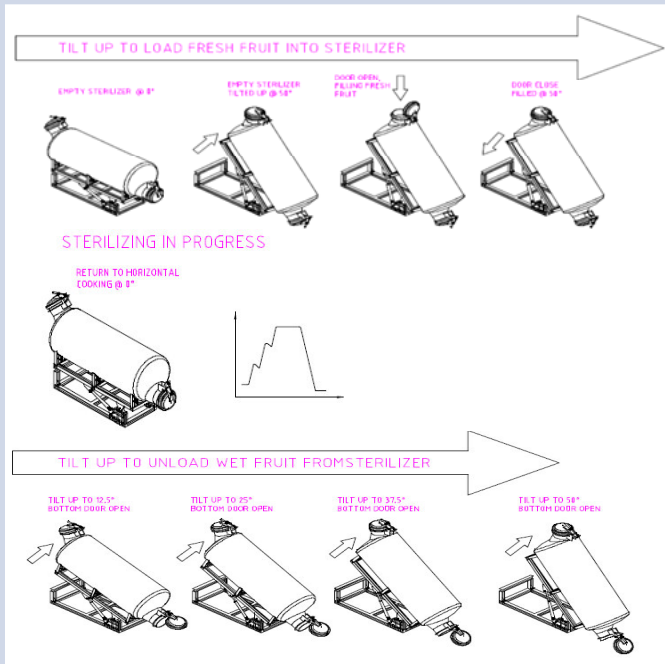

Typical Valves used in one lot of Sterilizer as following, which need to be automated.

A	Steam Inlet Valve
	8 " OKM 54MP Fully SS High Performance Butterfly Valve with <u>Metal</u> Seat c/w On/Off type Electrical Actuator with Auto Declutch-able Manual Override Hand wheel, Solenoid Valve, Mounting Bracket & Adaptor with matching flanges, bolts, nuts, washer and gasket
B	Steam Exhaust Valve
	8 " OKM 54MP Fully SS High Performance Butterfly Valve with <u>Metal</u> Seat c/w On/Off type Electrical Actuator with Auto Declutch-able Manual Override Hand wheel, Solenoid Valve, Mounting Bracket & Adaptor with matching flanges, bolts, nuts, washer and gasket
C	Condensate Valve
	8 " OKM 54MP Fully SS High Performance Butterfly Valve with <u>Metal</u> Seat c/w On/Off type Electrical Actuator with Auto Declutch-able Manual Override Hand wheel, Solenoid Valve, Mounting Bracket & Adaptor with matching flanges, bolts, nuts, washer and gasket
D	Flushing Valve
	4 " OKM 54MP Fully SS High Performance Butterfly Valve with <u>Metal</u> Seat c/w On/Off type Electrical Actuator with Auto Declutch-able Manual Override Hand wheel, Solenoid Valve, Mounting Bracket & Adaptor with matching flanges, bolts, nuts, washer and gasket
E	Purge Valve
	2" 3Pcs Body Fully Stainless Steel Ball valve with BSPT thread end and ISO 5211 Mounting Pad On/Off type Electric Actuator with Auto Declutch-able Manual Override Hand wheel
F	By Pass Drain Valve

Sterilizer Manufacturer:

- Up-Down Sterilizer in Indonesia: PT.Panca Bangun Reksa
- Tilting Sterilizer in Malaysia : Besteel Bhd



Tilting Sterilizer Auto Controller

One Eaton (Hardware and Software)

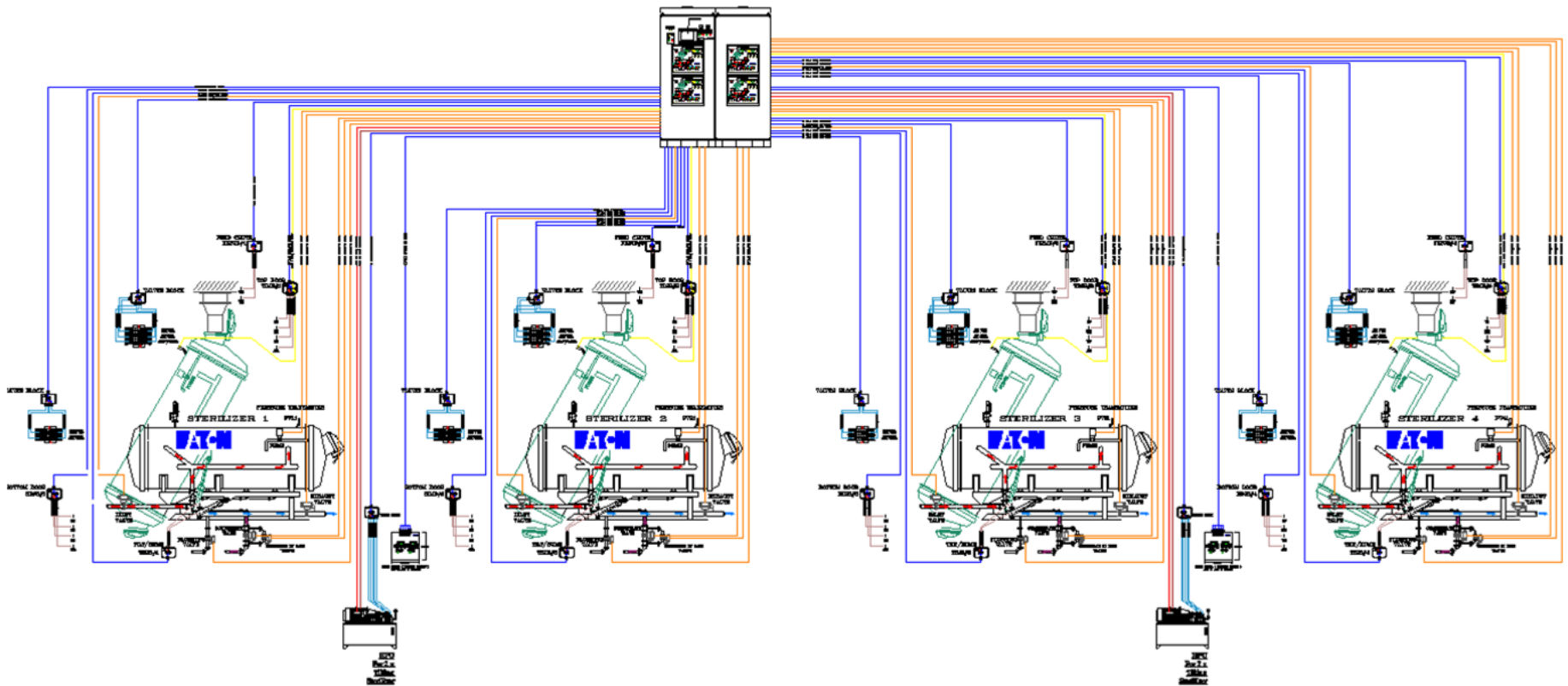

Grouping 4 x Tilting Sterilizers with Steam Valves w/ either pneumatic or electrical actuator

Ball Tipper Sterilizer - Hydraulics Systems and Interlocked Process Control

Ball Tipper Sterilizer is a unique design of Sterilizer in Ball Shape operated like Tipper. Each Sterilizer is about 60 ton Gross Weight and with a diameter of 3.5m that would hold 30ton fruit.

Feeding of FFB is via FFB Conveyor via Chute to one Sterilizer Clutched Door, where when sterilization is done, sterilizer is rotated to underneath hopper to discharge the Sterilizer Fruit Bunch.

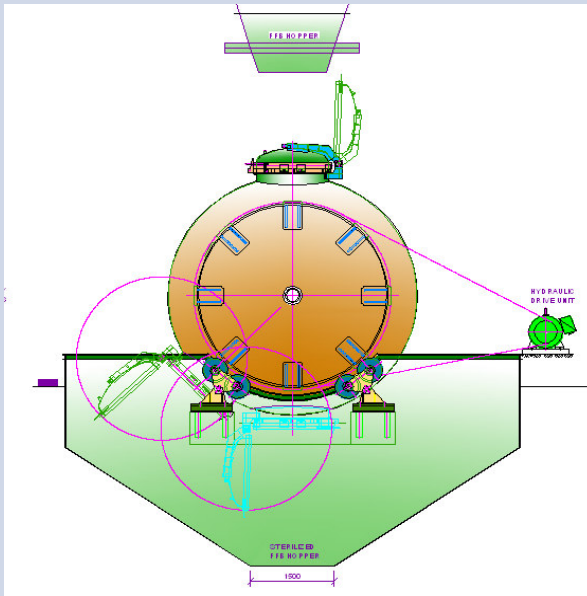

Hydraulic system used in this application required a hydraulic power unit (HPU), to rotate the Ball Tipper as well to operate the sterilizer clutched door.

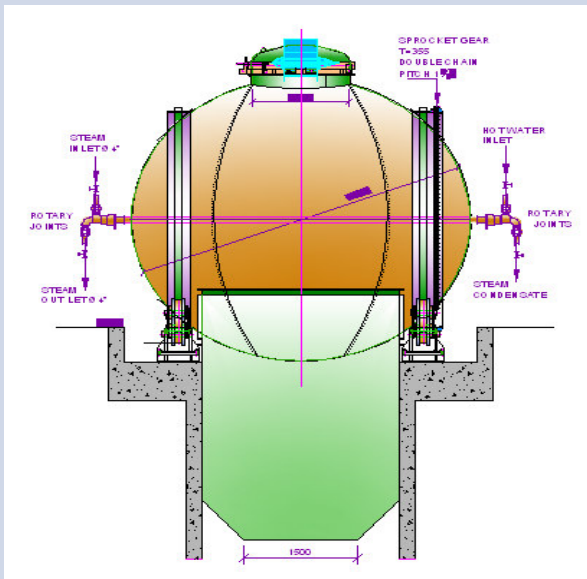

The only Sterilizer Manufacturer:

- Ball Tipper Sterilizer in Indonesia: PT.EraCipta BinaKarya



Automatic Back Pressure Receiver Systems

Eaton Automatic Back Pressure Receiver Systems Control is for *topping up (make up) of steam* to BPR in the event of low pressure in the vessel and *discharge (exhaust) of steam* when the steam is in excess.

The make-up valve (with assumption the upstream pressure shall be 19-23 barg and the downstream pressure of 1-4 barg) and the maximum flow rate 15,000 Kg/hr.

The receiver's steam will top-up through a PLC base controller with **PID (Proportional, Integral and Derivative)** algorithm where the action is accelerated if the pressure within the back pressure receiver is much below the set pressure and vice versa. The control will stop its action if the inlet steam falls below the preset minimum value and shall remain active if the steam inlet pressure is above the minimum preset pressure for the inlet pressure. On the other hand the top-up process also accelerated if there is an immediate demand for steam at the sterilizer.

The turbine operation may take into operation. If the turbine runs, low line pressure disables the make-up and in the absence of turbine, it run irrespective the line pressure of the main steam line.

Steam Make Up Valve

3(Three) " Globe Control Valve c/w Pneumatic Actuator (Positioner) a delta-P of approximately 29 Bar with positional controls (4-20mA). – Full Modulating Valve, Mounting Bracket & Adaptor with matching flanges, bolts, nuts, washer and Gasket

Steam Exhaust Valve (Surplus Valve)

6(Six) " Fully SS High Performance Butterfly Valve with Metal Seat c/w Pneumatic Single Acting Actuator with Declutch-able Manual Override Hand wheel, EP Positioner (Full Modulating, 4-20mA) and mounting Bracket & Adaptor with matching flanges, bolts, nuts, washer and gasket

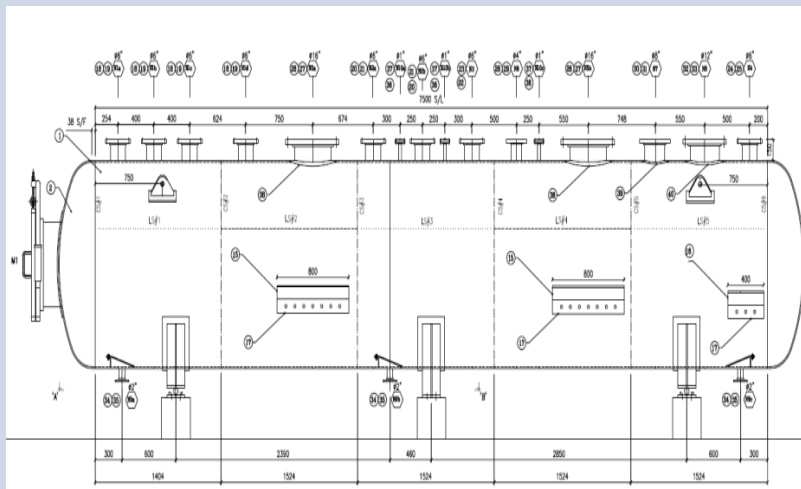

Biomass Boiler – Fuel Moving Floor (or Walking Floor)

Fuel Moving Floor is designed to suit the fuel made available from the mill itself. Example for 30 MT/hr Boiler @20bar. Fuel made available from 45t FFB/hr Palm Oil Mill. Estimated raw material of fuel is mixture of FFB 10Ton, Fiber 29Ton and shell 3Ton. Typically boiler requires a 35~38% fuel mix which translate to about 15Ton/hr with a mix ratio of dried & shredded EFB 3Ton (20% Max), shell 3ton and fiber 9Ton (80%). For two hours fuel storage on Walking Floor Hopper with average density of Fuel 275kg/Mtr³ had determined the 2 section of 4Mtr x 4Mtr x 10Mtr bunker.

The system is easy to set-up and installation and also lower in maintenance. Our approach on sizing of Fuel Moving Floor application for sufficient fuel storage and efficient retrieval of fuel to maintain boiler pressure irrespective of interruption of fiber and shell supply from process. This is to ensure boiler pressure can be maintained at all times, thus turbine operation will be smooth and process steam uninterrupted.

Hydraulic system used in this application required a hydraulic power unit (HPU) to drive a two cylinders, which is working independent of the other. This cost effective with ready-to-use & easy-to-install package system could be customized to suit the requirement.

The proposed architecture for the Fuel Moving Floor :

- A fuel moving floor hopper comprises of section of floor slabs each controlled by two hydraulic cylinder. The moving floor can have multiples or sets of moving slabs according to the needs and buffer capacity for the fuel delivery system. Fibers retrieval from the storage shall be pushed to the hopper by pay-loader or any other pushing equipment.
- The fuel from the moving floor system is fed to the fuel feeding conveyors to the boiler through the dropping chutes on the screw feeding conveyor. The dropping chutes have an individual hydraulically controlled door that regulates the amount of feed to the horizontal feeding screw conveyor under the chute. The chute opening is geared to the speed of the screw conveyor and the speed of the proportional controlled screw conveyor is governed by the boiler pressure (or demand).
- Excessive fuel will return to the moving floor hopper through the return conveyors.

The overall systems typically shall consist of:

Fuel storage/ drying area

The area should be airy with good ventilation so natural de-hydration can easily take place. The design shall allow ease of movement for the heavy vehicles like pay-loader (or even truck if required to ferry bio-mass from external).

Delivery hopper

The capacity of the delivery hopper shall suit the operational requirement allowing a smooth operation of walking floor without stoppage for maybe 1~2 hours. The capacity of the hopper shall be calculated basing on the expected fuel consumption for the proposed boiler(s).

Leveler

There shall be two levelers system for the system namely the discharger control leveler and the storage leveler. The former is to regulate the volumetric delivery for the bio-mass into the boiler feed conveyor and the later is to ensure the stored bio-mass is evenly distributed in the storage bin.



Biomass Boiler – Fire Gate

Hydraulic systems for Biomass Boiler – Fire Gate is typically supplied to various Boiler Maker.

A reciprocating fire grate with automatic ash conveying is used to handle fuels that are physically abrasive, mineral-rich, and contain low ash melting temperature.

Using this reciprocating method, grate temperature could be controlled and manual raking is not necessary.

Hydraulic system used in this application required a hydraulic power unit (HPU) to drive a multiple cylinders, which is working independent and/or simultaneously. This cost effective with ready-to-use & easy-to-install package system could be customized to suit various Boiler OEM's requirement.

Controls: a PLC Control Panel with program to control various cylinder movement

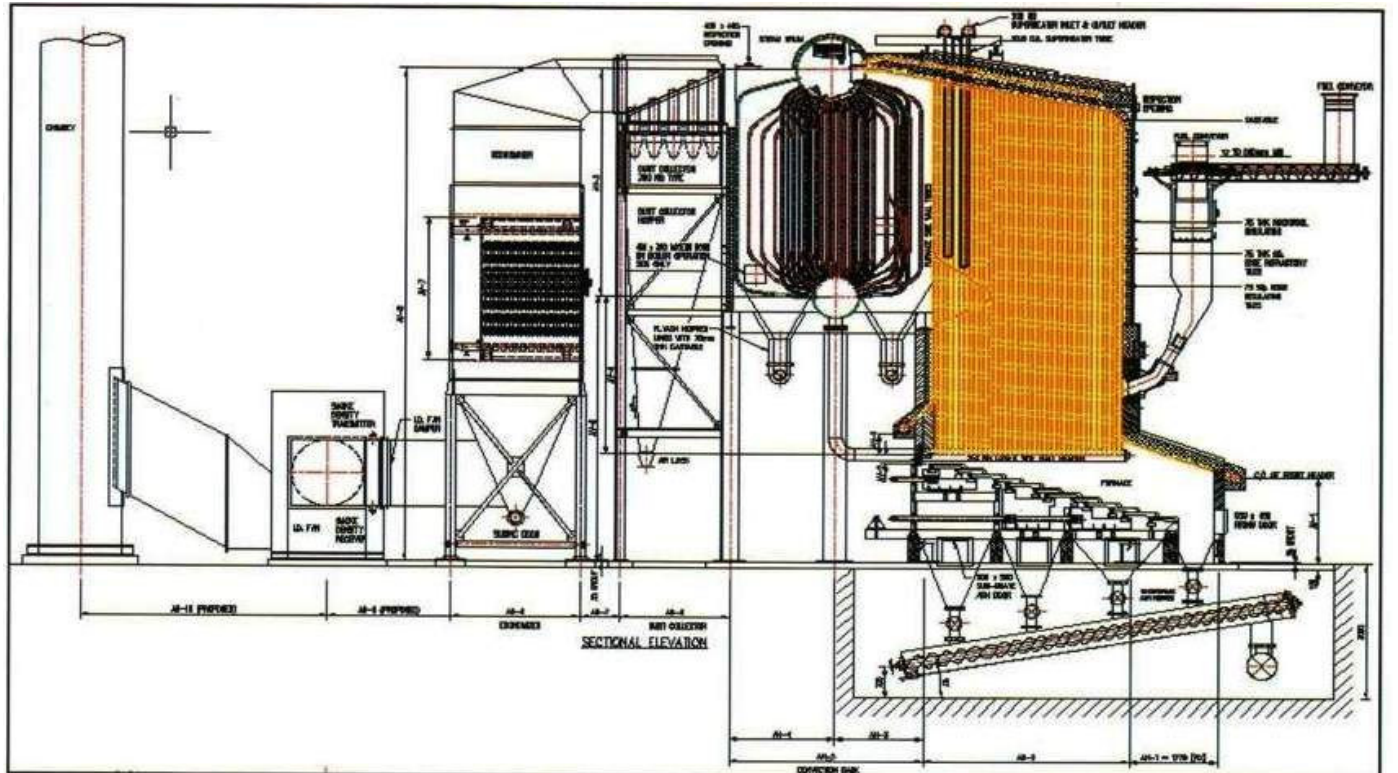

Screw Press Cone Control – Stand Alone Panel

Automatic Current Control (ACC) v.3

ACC v.3 screw press system is the low cost Cone Control Panel that is operating by sensing input signal (High and Low - Current - Ampere) from the main electric motor gearbox and feedback electronically to the Panel, which regulates the cone pressure respectively to signal received.

- 2 presetting ampere controls
- Ongoing current sensing to minimize oil loss
- An instant tripping c/w reset (the off position of Auto/Off/Manual switch) for press motor on overloading
- Automatic function. Human errors and labor is generally reduced, Manual override also available
- Proven in the market.
- Programmable Digital Ampere Meter provides two different press motor current setting control

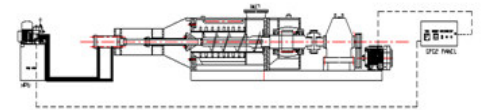

Multi-Ampere Control (MAC) v.1

MAC v.1 screw press cone control hydraulic system is an improved version of ACC v.3. The system operates by sensing input signal (Hi-Hi and Low-Low - Current - Ampere) from the main gearbox electric motor and feedback electronically to the PLC in the Panel, which regulates the cone pressure respectively to signal received providing an automatic pressing. MAC v.1 provides easy three presetting ampere control for operator to manipulate the press cone pressure control.

- 4 presetting ampere controls for various pressure control requirements
- Ongoing current sensing and pressure sensing to minimize oil loss
- An instant tripping c/w reset (the off position of Auto/Off/Manual switch) for press motor on overloading
- Automatic function. Human errors and labor is generally reduced, Manual override also available
- Proven in the market.
- User friendly Touch Screen controlled by PLC



Automatic Proportional Reaction (APR) v.3a

APR v.3a proportional reaction is the original Eaton design to provide a much better cone response in relation to the main drive motor ampere to further reduce oil loss. This system operates by sensing input signal (ampere) from the main screw drive electric motor and amplified electronically to activate the electro-hydraulic pressure relief valve, which regulates the cone pressure proportionally based on 4-20mA signal to provide a continuous **automatic closed loop constant pressing**. A PLC with adequate analog/digital inputs and outputs provide more control and monitoring functions, which can be easily programmed by a user-friendly dialog terminal comprising of an interactive HMI touch screen.

- Consistent current sensing together with pressure sensing to have minimize oil loss
- An instant tripping c/w reset (the off position of Auto/Off/Manual switch) for press motor on overloading
- Fully automatic function. Human errors and labor is generally reduced
- Manual override available
- Proven in the market. Dryer fruit fiber and reduced oil loss and nut breakage
- User-friendly HMI Display with built in PLC program
- Two level of setup access allow developer and user to program System Setup and Operation Setup respectively



Novaflow Engineering Sdn Bhd

18-1 Jalan Putra Mahkota 7/8D
47650 Subang Jaya
Selangor Darul Ehsan, Malaysia.
Tel : +603-5192 2569/4569
Fax: +603-5192 5569
Email: sales@novaflow.com.my

Novaflow Engineering Miri Sarawak

Lot 5214 Desa Indah 3, Permyjaya 98009
Miri Sarawak, Malaysia.
Tel/Fax: +6085-628569

Email: service@novaflow.com.my



Eaton Industries

Eaton Industries Pte Ltd

Industrial Sector

Singapore Office

Eaton Building
45 Tuas View Circuit
Singapore 637660
Tel: +65 6861 1120
Fax: +65 6862 1225

Indonesia Office

Menara Bidakara 2, 9th Fl
Jl. Jend. Gatot Subroto Kav.71-73
Pancoran - Jakarta 12870
Indonesia
Tel: +62 21 2949 9000
Fax: +62 21 2949 9001

Eaton Industries Sdn Bhd

Malaysia Office

Pavilion Kuala Lumpur
Level 8, 168 Jalan Bukit Bintang
55100 Kuala Lumpur, Malaysia
Tel: +603 9205 8599
Fax: +603 9205 8598



For more information, please contact EHSEA Green Team at sghyd_se@eaton.com or visit the website below:
www.eaton.com/hydraulics www.eaton.com/electrical